

### SPECIFICATIONS:

**MODEL NUMBER:**

**PUMP DESIGN:** Positive Displacement 3 Chamber Diaphragm Pump

**CHECK VALVE:** (1-Way Operation) Prevents Reverse Flow

**CAM:** 3.0 Degree

**MOTOR:** Permanent Magnet, P/N 11-160-10, Thermally Protected

**VOLTAGE:** 230 VAC Nominal

**PRESSURE SWITCH:** Factory Set @ 45 PSI Shut-Off, Turn On 25 ± 5 PSI

**LIQUID TEMPERATURE:** 130 Degrees Fahrenheit (54 Degrees Centigrade) Max.

**PRIME:** Self-Priming Up To 9.0 Ft. Vertical,  
Max. Inlet Pressure 30 PSI (2.1 Bar)

**PORTS:** 1/2" - 14 Male Parallel Thread

**MATERIAL OF CONSTRUCTION:**

**PLASTICS-** Polypropylene

**VALVES-** Santoprene

**DIAPHRAGM-** Santoprene

**FASTENERS-** Zinc Plated Steel

**NET WEIGHT:** 5.0 Lbs (2.27 Kg)

**DUTY CYCLE:** Intermittent (See Temp. Rise Chart)

**TYPICAL APPLICATIONS:** Water Delivery

**APPROVALS:** N.S.F. Listed, UL Recognised

### DIMENSIONS:

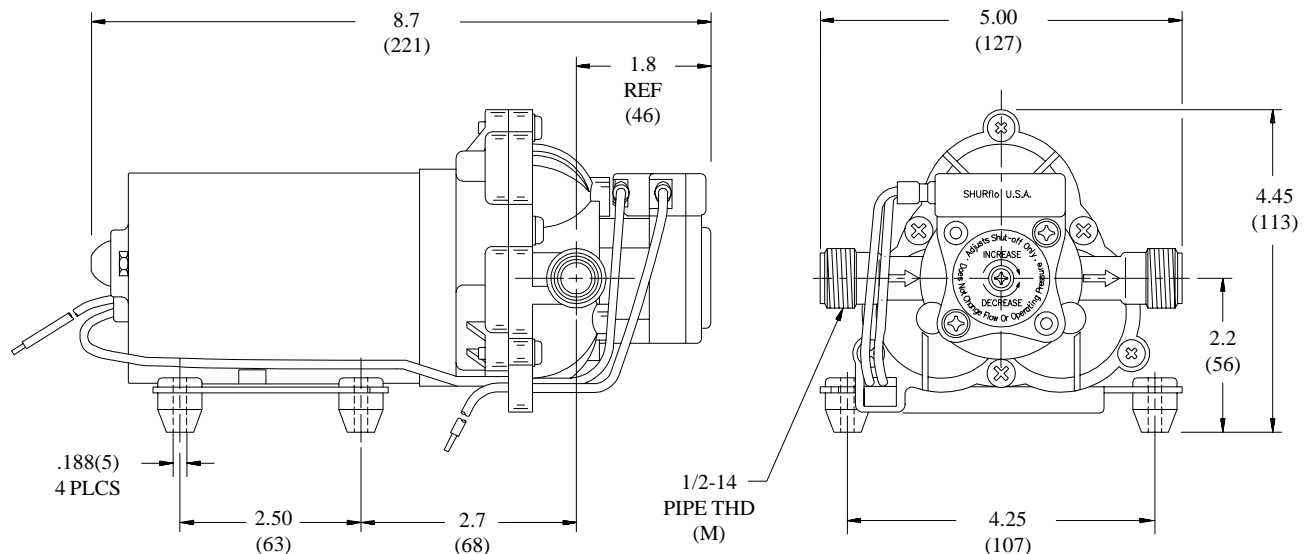

**TEMPERATURE RISE**

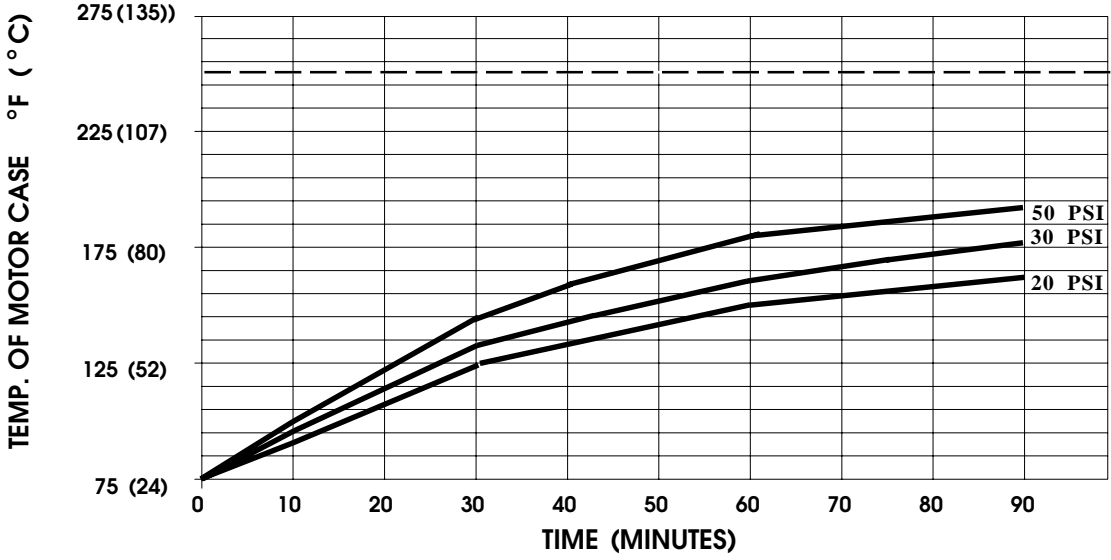

THIS GRAPH IS FOR USE AS A DESIGN GUIDE. IT IS BASED ON RUNNING CONTINUOUSLY WITH AN AMBIENT TEMPERATURE OF 75° F IN STILL AIR. THE THERMAL BREAKER WILL OPEN WHEN THE CASE TEMPERATURE REACHES 250° F.

[----- TRIP POINT OF THERMAL PROTECTOR]

**TYPICAL PERFORMANCE**

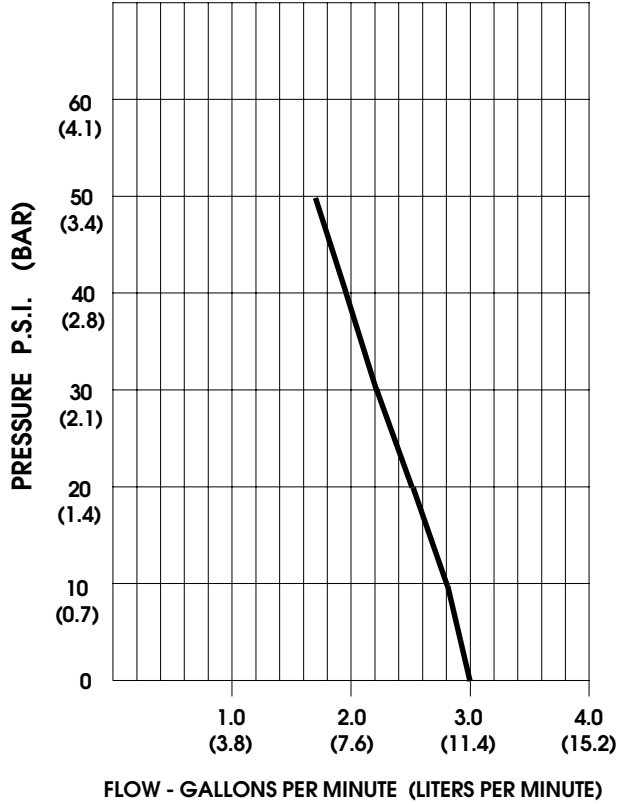

PRESSURE (PSI)	FLOW (GPM/LIT)	RPM MIN/MAX	CURRENT (AMPS)	VOLTAGE (VOLTS)
OPEN	3.00/11.3	2140/2150	.30	230VAC
10	2.80/10.6	2115/2140	.35	"
20	2.50/9.5	1995/2010	.45	"
30	2.20/8.3	1895/1910	.50	"
40	2.00/7.6	1795/1825	.55	"
50	1.70/6.4	1695/1755	.60	"

*-SPECIFICATIONS SUBJECT TO CHANGE WITHOUT NOTICE.  
-ALL DATA BASED ON TESTING WITH WATER.*